

1. TPS_Demo_KIT顶层原理图

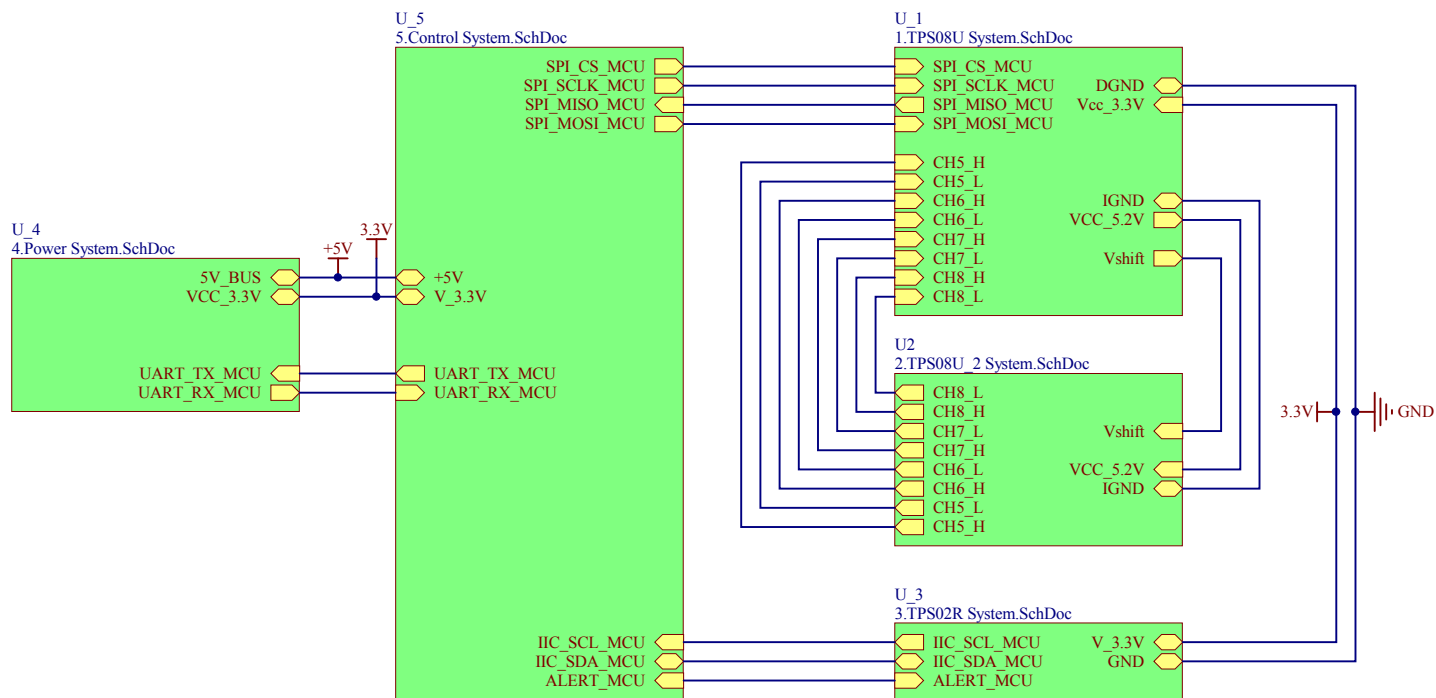

#	修改日期	修改内容
1		
2		
3		

1. TPS08U采集前端电路1

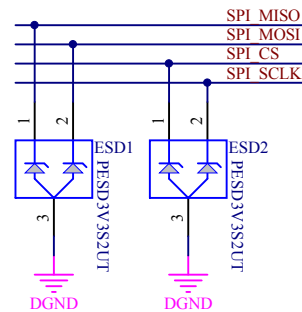
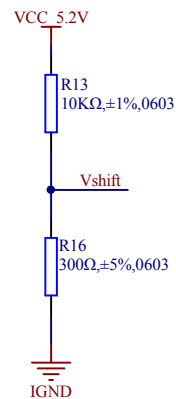
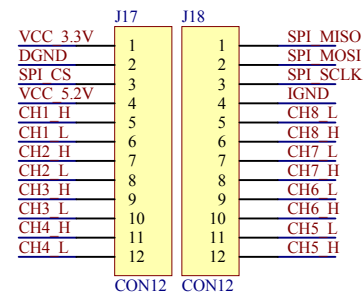
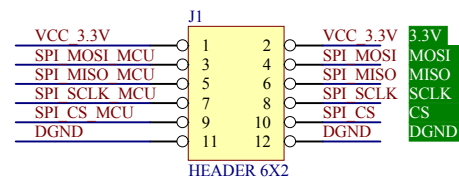
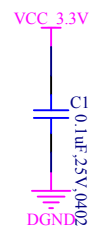
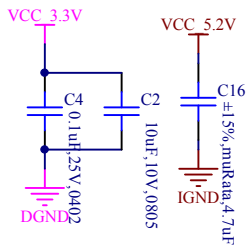
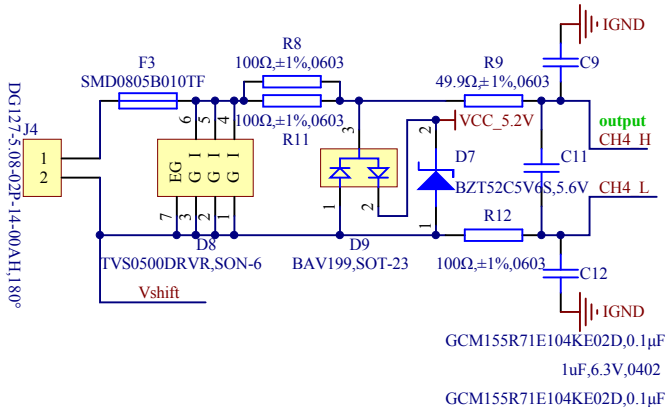
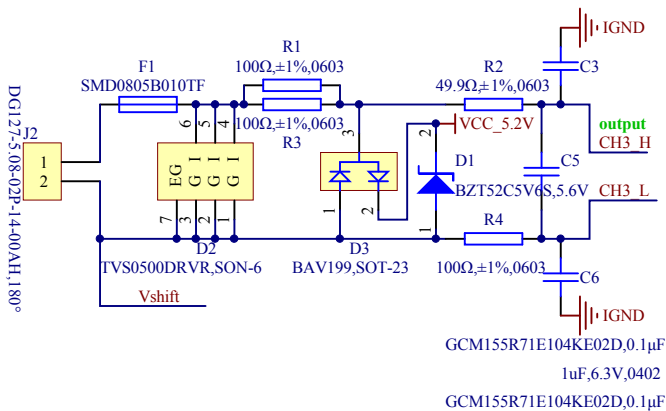
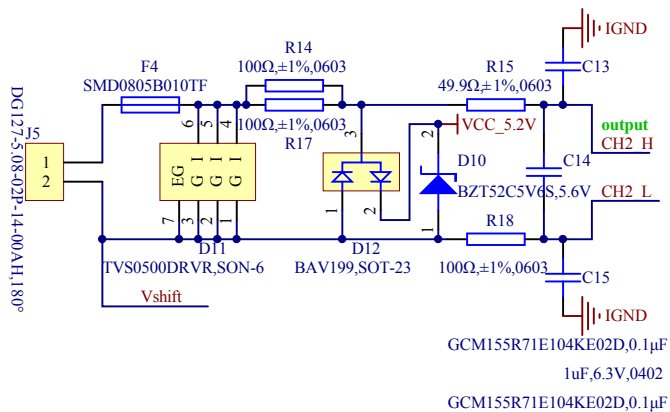
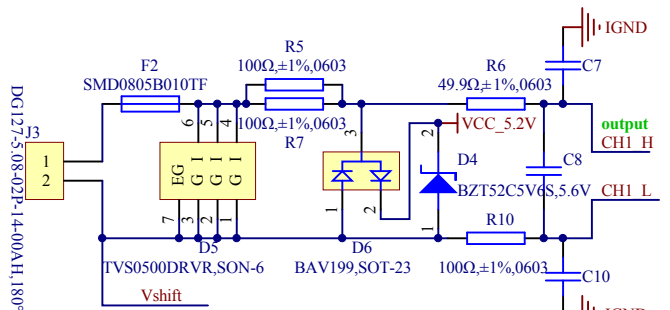
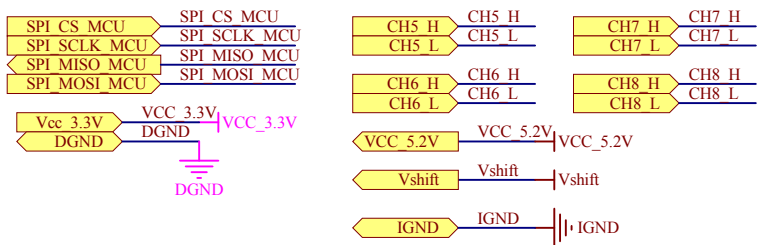

#	修改日期	修改内容
1		
2		
3		

2. TPS08U采集前端电路2

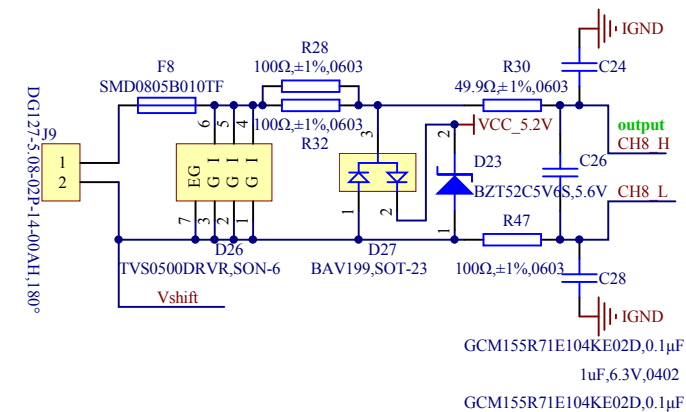
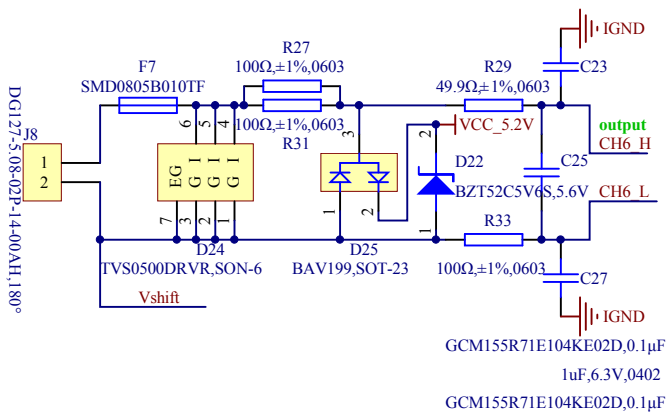
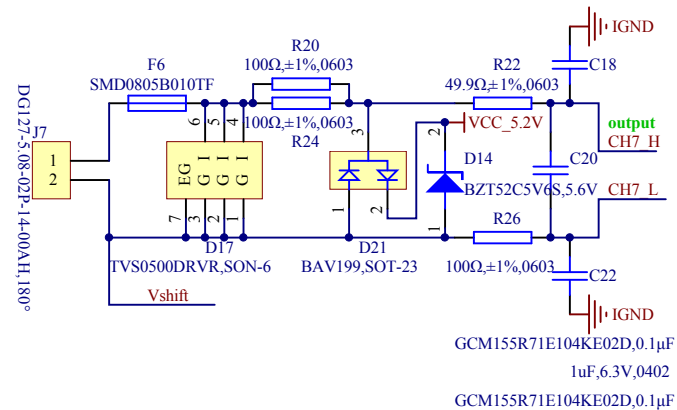
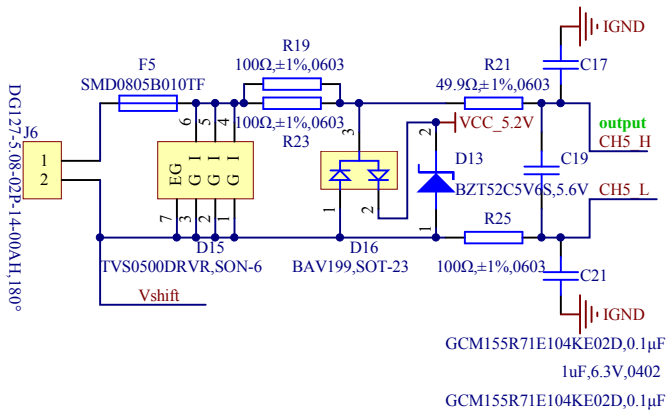
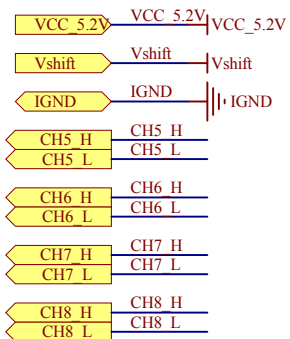

#	修改日期	修改内容
1		
2		
3		

3. TPS02R采集前端电路

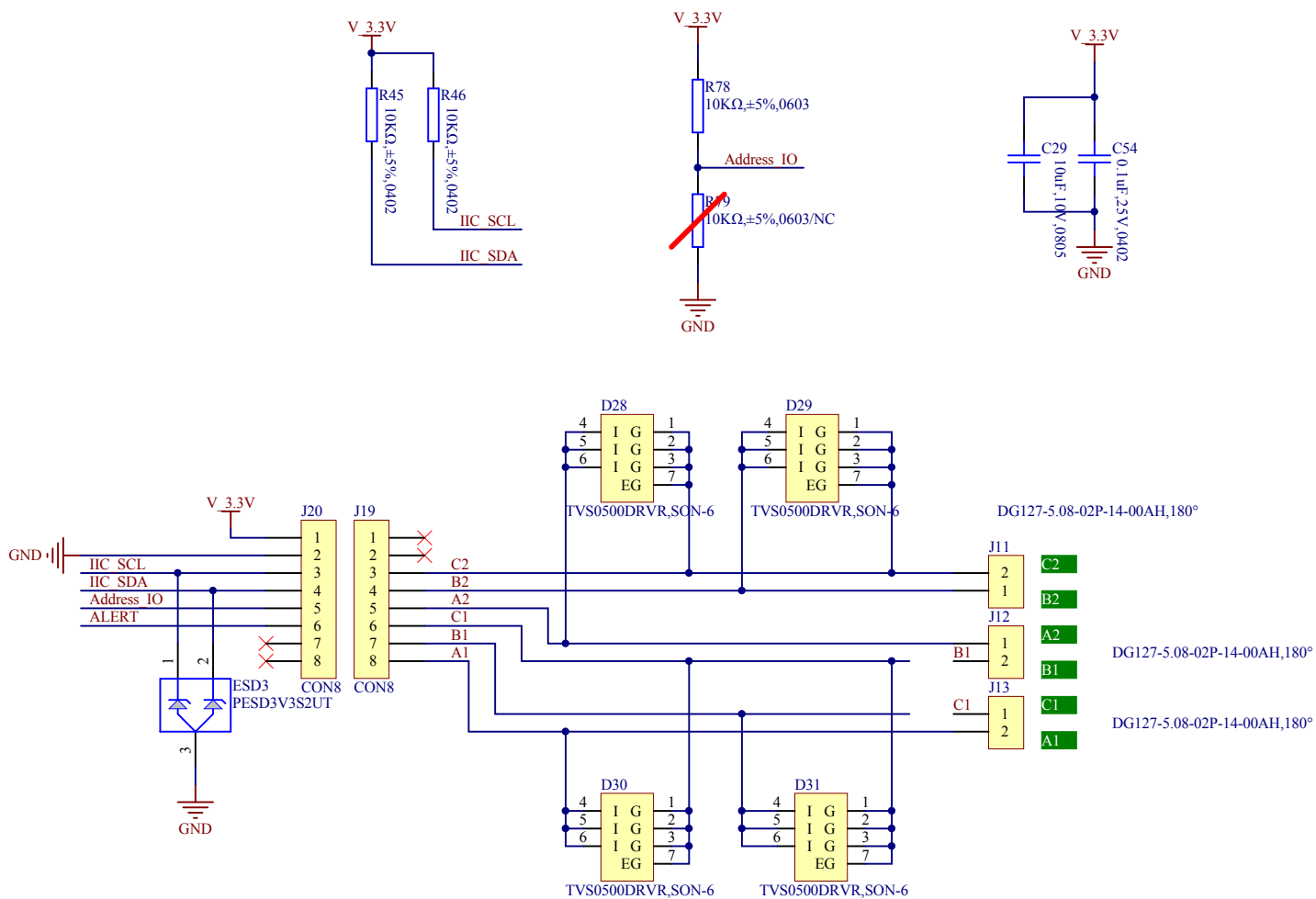
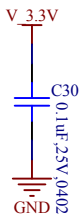
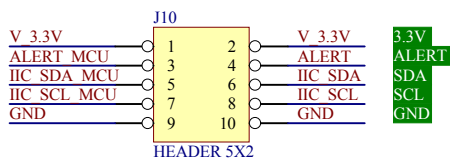
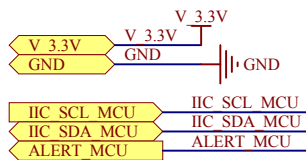

#	修改日期	修改内容
1		
2		
3		

5. 微处理器控制电路

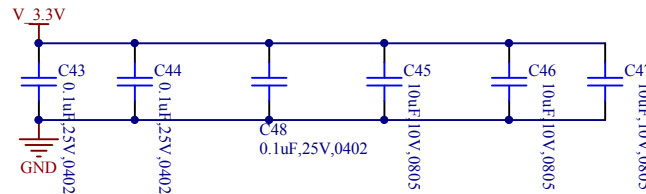
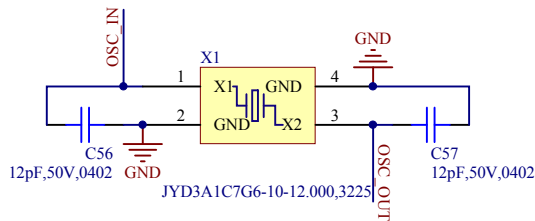
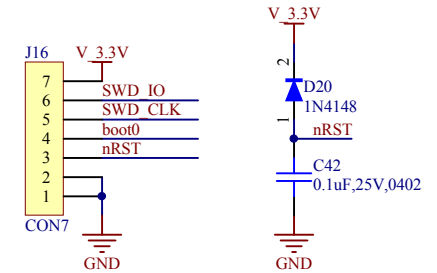
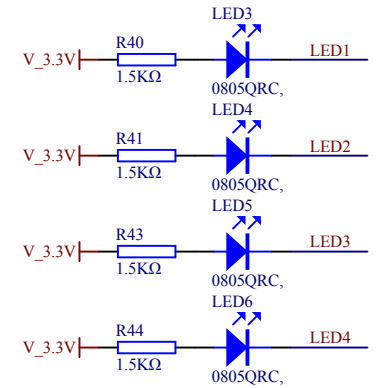
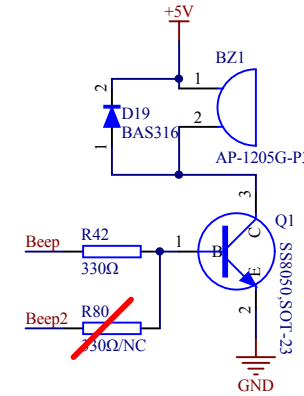
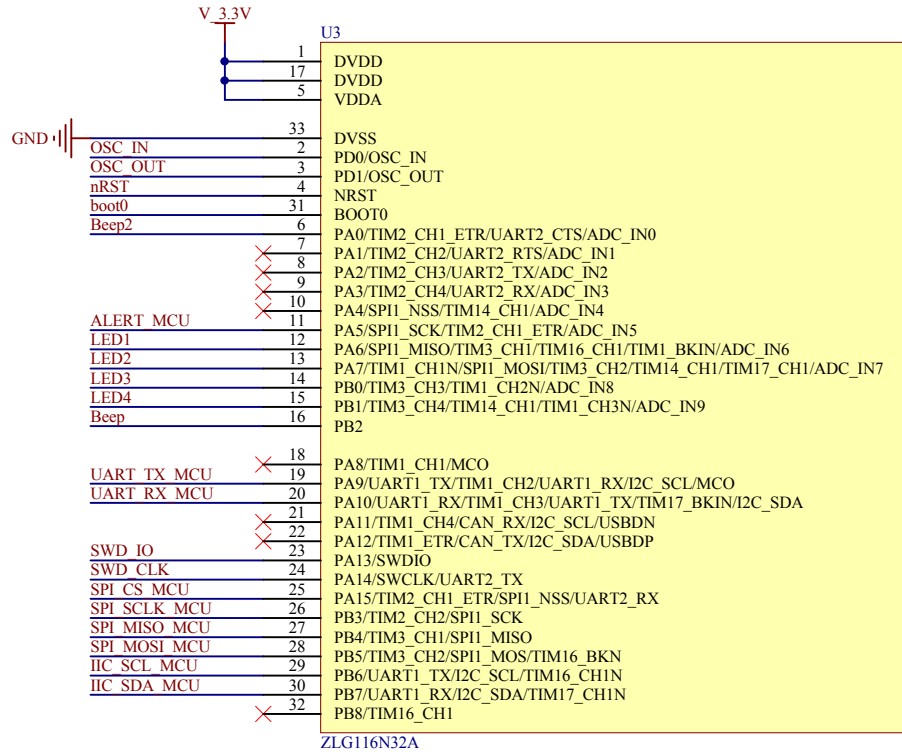
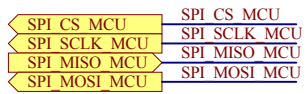
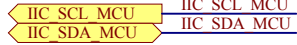
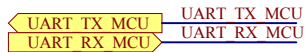
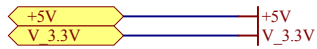

#	修改日期	修改内容
1		
2		
3		